



LED 360 Post-top Luminaire

360 series post-top is a modern design LED luminaire for column/post mounting at heights of 4 - 8m. IP65 design for exterior environments such as car-parks, pathways and pedestrian areas. High uniformity across a range of spaces and reduced light spillage, thus further enhancing this 95lm/W luminaire to give optimum lux levels throughout. Furthermore, luminaire compatible with standard mains photocells.

Additional benefits as well as +55,000hour maintenance free performance, include minimal disturbance to nocturnal wildlife to the lack of UV/IR spectrum associated with LED photometric characteristics.

Unit complete with base mount for 60mm (78mm available on request) column-entry hence universally compatible.

Product information

Durable with rated life span of +55,000 hours / No UV or IR emissions / Instant Illumination & Flicker free / CE & RoHS international standards / Environmentally friendly & part recyclable: no mercury or other hazardous materials used / Heavy duty diecast aluminum housing & 2mm toughened PC optics / Complies with EN60598

Code	Nominal Size	Lumen Output	Power Consumption	Weight	Equivalent
SD360PT-050	Ø620mm x 520mm	4,800lm	50W	6.5 KG	70W MHL/ 150W SON



Natural White

Other colours are available on request

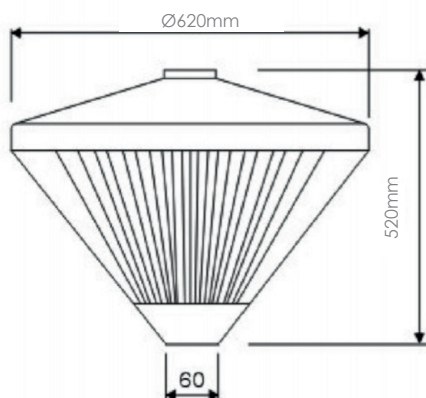

Technical Specifications

Beam Angle: 120°

Luminous Efficacy: up to 95lm/W

Input Voltage: 100-280V AC

High Colour Rendering Index: >80Ra

Mounting: Ø60mm bottom column-entry (78mm available on request)

Power Factor: ≥0.96

LED Type: SMD3030 LEDs

Operating Temperature: -20°C to 50°C

Colour Temperature: NW 4000K (others on request)

LED Post-top 360 Series

Natural White