

SEDNA[®]

l i g h t i n g



LED in-ground - Single Colour

LED in-ground lights add that sparkle to any contemporary project or feature. Using a 3 pcs of 1.2 Watt high power LED, accent lighting can be mounted in floors, walls and other flat surfaces, with **minimum disturbance to the practicalities of surroundings (ie. walkover)**. Complete series of fittings can be connected via junction boxes. Stainless steel fascia with 5mm tempered glass ensures IP67 waterproofing and corrosion free. Controlled with standard 12V DC LED controllers / DMX512-RGB decoder. Polycarbonate mounting cup for ease of installation.

Product information

Durable with rated life span of +30,000 hours / No UV or IR emissions / CE & RoHS international standards / Environmentally friendly & part recyclable: no mercury or other hazardous materials used / Stainless steel fascia with 5mm tempered clear glass cover / Supplied with mounting cup

Code	Size	Lumen Output	Power Consumption	LED Quantity
SDIG-3W-S	150mm x 140mm	390 - 410lm (White)	3.6W	3pcs

LED in-ground - RGB

LED 3.6W in-ground lights are capable of RGB colour changing functionality using standard 12V LED accessories.

Code	Size	Lumen Output	Power Consumption	LED Quantity
SDIG-3W-RGB	95mm x 123mm	280 - 300lm (White)	3.6W	3pcs (R:1/G:1/B:1)

Available in the following stock lumen finishes:

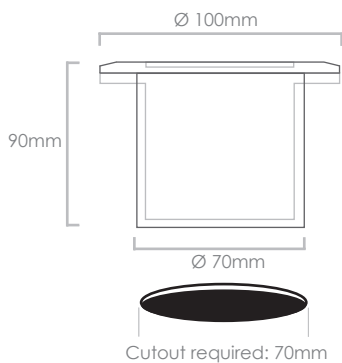
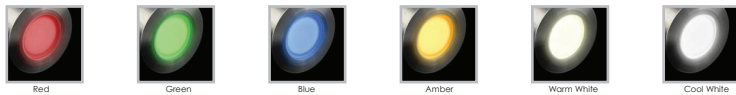

Technical Specifications

Beam Angle: 45°

Operating Voltage: DC 12V

LED Type: Epistar High-power 1.2W LEDs

Operating Temperature: -20°C to 50°C

Colour options: -RGB (16 million colours)

-Single colour: Red
Blue
Green
Amber
Warm White
Cool White



In-ground LED
3.6W

RGB / Single Colour